



## Besam Balance Door System BDS

### **Perfect for narrow passage ways**

The Besam automatic balance door has incorporated the advantages of both conventional swing doors and normal sliding doors. Constraints of safety and reliability with many door installations mean that the balance door will often be the only natural solution. Wherever there is minimal space for a door leaf that swings open, there is no other alternative than the balance door.

### **Perfectly balanced**

The balance door is less vulnerable to severe wind loads, cross-draughts as well as pressure differences. The door is always perfectly balanced

despite the lateral pressure and this ensures that it is easily opened even during severe conditions.

### **Built-in safety, reliability and economy**

The balance door is completely suspended in the frame without guide grooves in the floor. This is a method which is functional and safe and at the same time economical in both installation and maintenance. Finger guards between the door leaf and the jamb reduce the risk of accidents.

### **Small but strong**

The BDS-system can be equipped with the highly reputed Besam door

operators. The operators have been designed to cope with the toughest conditions. Strong gusts of wind, heavy doors or intensive traffic flows pose no problems.

### **Design**

The Besam balance door system is always tailor-made to suit differing customer requirements, and has a stable and functional construction. The system is pre-fabricated to ensure that all parts are a perfect fit when installed on the site. The door system is delivered complete with jamb and glazed door(s). The operator with arm system is to be ordered separately.

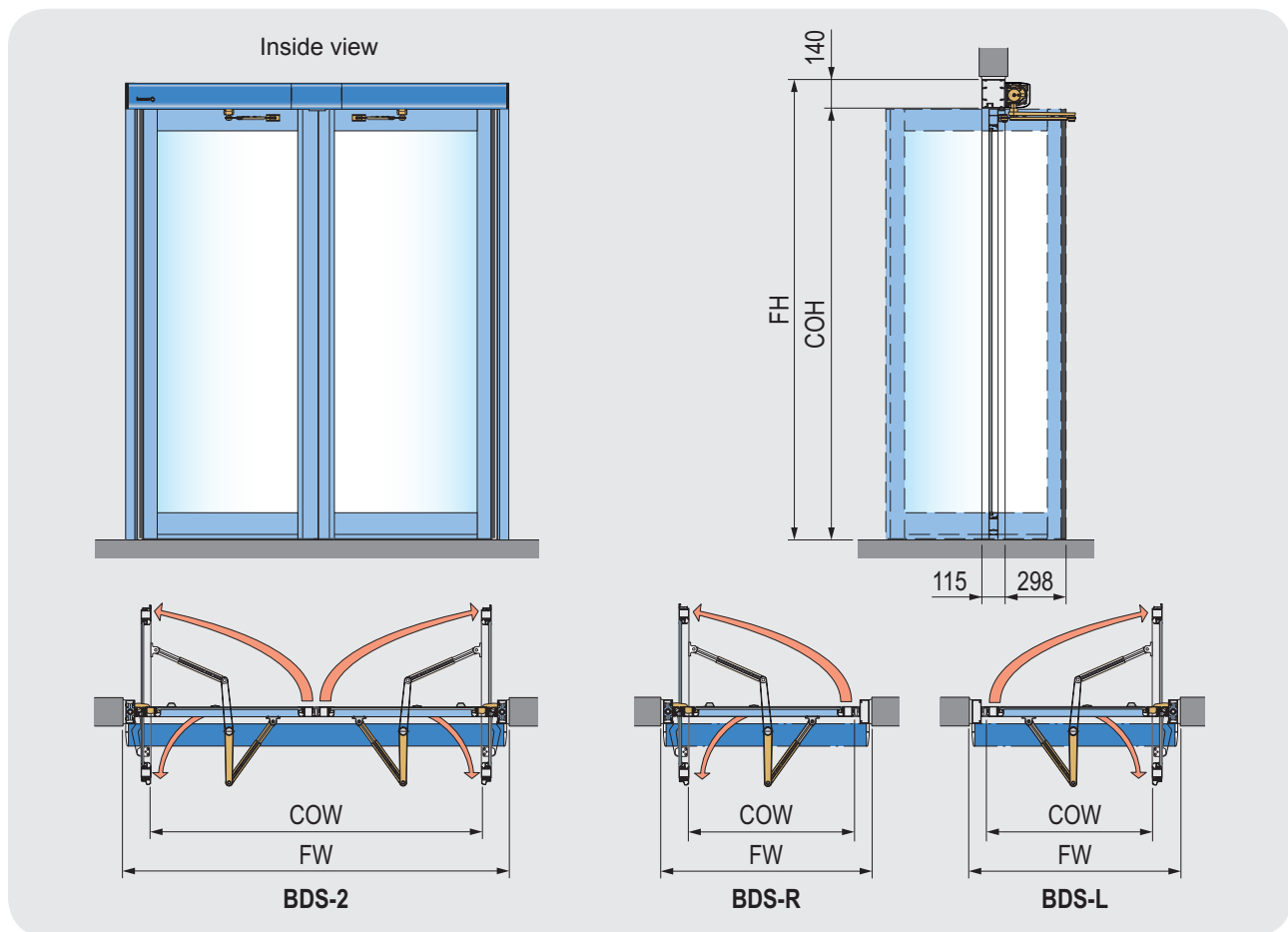

## Technical Data Besam BDS

### Models

- BDS-L: Left hand door; a complete unit consisting of jamb/header assembly and door leaf
- BDS-R: As BDS-L, but right hand door
- BDS-2: Double doors; a complete unit consisting of jamb/header assembly and door leaves

### Sizes

Type	FW min	FW max	COH min	COH max
BDS-L	840	1170	1950	2200
BDS-R	840	1170	1950	2200
BDS-2	1560	2240	1950	2200

Clear opening width (COW) = FW-190 (BDS-L/R) and FW-250 (BDS-2)  
All dimensions in millimetres

### Standard equipment

- Jamb with outer dimensions 45x114 mm made from clear anodized aluminium
- Door leaves, with 8 mm laminated glass, made from clear anodized aluminium, thickness 48 mm
- Finger protection rubber extrusion

### Accessories and Options

- Door operator and arm system
- Other paint finishes optional
- The Besam range of activation units
- Programme selectors
- Door position indicator
- Thermo glass, thickness 22 mm (6-10-6)

- Mechanical hook bolt lock on the door leaf
- Electromechanical lock
- Espagnolette lock
- Midrail

### Technical specifications

See operator product sheet

Besam Export AB, Box 669, SE-261 25 Landskrona, Sweden

Tel: +46 418 514 00 Fax: +46 418 513 55

export@besam.se • www.besam.com